

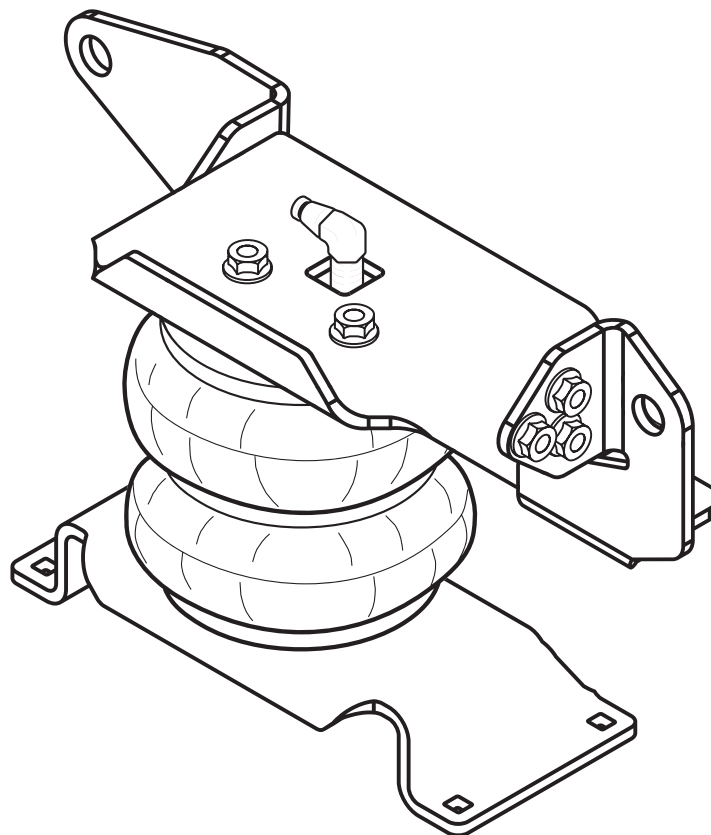

riderite.com

# INSTALLATION INSTRUCTIONS



**Firestone**

*World's Number 1  
Air Spring.*



FIRESTONE INDUSTRIAL PRODUCTS COMPANY

# ! IMPORTANT

*PLEASE DON'T HURT YOURSELF, YOUR KIT OR YOUR VEHICLE. TAKE A MINUTE TO READ THIS IMPORTANT INFORMATION.*

**DO NOT INSTALL IF THE TRUCK HAS BEEN LIFTED AND THE STOCK JOUNCE BUMPER SPACERS ARE NOT ON THE VEHICLE.** *This kit is to be used on a **pickup truck only**, and **DOES NOT INCREASE YOUR VEHICLE'S MAXIMUM LOAD.***

## **SAFE INSTALLATION**

Please take all safety precautions during installation. A hydraulic jack can fail, and if that happens, you can be seriously hurt, or worse, if you are relying on it to hold up the vehicle. If you use a hydraulic jack, secure jack stands in the appropriate locations and chock any tires still touching the ground.

Wear safety glasses or goggles. Your eyes may be lower than some parts and pieces, and you don't want to lose an eye.

Remove the possibility of any electrical issues by disconnecting the negative battery cable.

## **KIT CLEARANCE**

There must be a minimum of 1/2" clearance around all installed components when the Air Springs are inflated and under a load. The Air Springs must flex and expand during operation, so the clearance keeps the kit from rubbing against parts of the vehicle.

## **VEHICLE GVWR**

NEVER exceed the maximum load recommended by the vehicle manufacturer (GVWR). The GVWR can be found in your vehicle's owner's manual or on the data plate on the driver's side door.

## **INFLATING THE AIR SPRINGS**

When inflating Air Springs, add air pressure in small quantities, checking air pressure frequently. The Air Springs have much less air volume than a tire, so they inflate much more quickly.

## **PRESSURE TO LOAD**

The Air Springs will support approximately 50 lbs. of load for each PSI of inflation pressure (per pair). For example, 50 PSI of inflation pressure will support a load of 2500 lbs. per pair of Air Springs.

## **APPROPRIATE AIR PRESSURE**

For best ride, use only enough air pressure in the Air Springs to level the vehicle when viewed from the side (front to rear). This will vary, depending on the load, location of the load, condition of the existing suspension, and personal preference.

## **OPTIONAL T-FITTING**

This kit includes Inflation Valves and Air Line Tube for each Air Spring, allowing you to compensate for unbalanced loads. If you prefer a single Inflation Valve system to provide equal pressure to both Air Springs, your dealer can supply the optional "T" fitting (Part # 3025 or WRI-760-3461 retail pack).



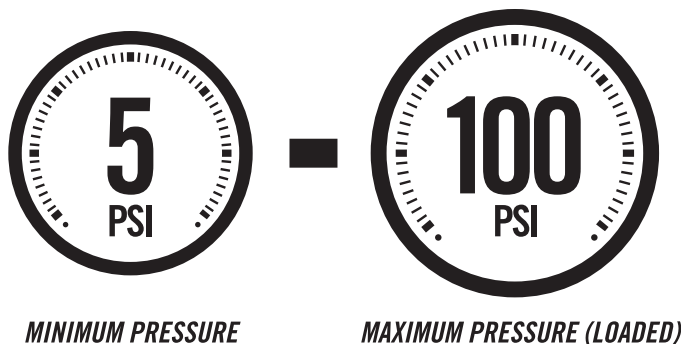



**ONCE INSTALLED SUCCESSFULLY, FOLLOW THESE PRESSURE REQUIREMENTS FOR THE AIR SPRINGS:**



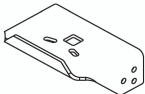
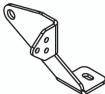
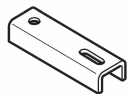

# PARTS

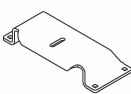
Compare the parts below to your kit. Ensure you have all pieces, and organize them for an easier installation.

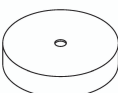













## MAIN KIT CONTENTS

PART # 6781	 x2 AIR SPRING	PART # 5857	 x1 LEFT REAR UPPER BRACKET	PART # 5086	 x4 1/2" BRACKET STRAP
PART # 5853	 x2 AIR SPRING UPPER BRACKET	PART # 5856	 x1 LEFT FRONT UPPER BRACKET	PART # 5859	 x2 1 1/2" BRACKET SPACER
PART # 5854	 x1 RIGHT REAR UPPER BRACKET	PART # 5858	 x2 LOWER BRACKET	PART # 9415	 x1 AIR LINE TUBE (22 FEET)
PART # 5855	 x1 RIGHT FRONT UPPER BRACKET	PART # 5336	 x2 AIR SPRING SPACER (see page 6 for important details)		

## A24-760-7560 INFLATION VALVE BRACKET KIT

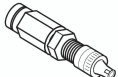
PART # 9483	 x1 NO-DRILL INFLATION VALVE BRACKET	PART # 9488	 x2 LARGE NYLON TIE
-------------	--	-------------	---

## A21-760-2600 HARDWARE PACK

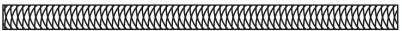
PT # 3338	 x12 3/8" - 16 x 1" HEX HEAD BOLT	PT # 3159	 x4 5/8" - 18 FLANGE LOCK NUT	PT # 3031	 x2 1/4" ELBOW AIR FITTING
PT # 3499	 x4 5/8" - 18 x 4" FLANGE BOLT	PT # 0075	 x20 5/8" FLAT WASHER	PT # 3073	 x4 3/8" - 16 x 6" CARRIAGE BOLT
PT # 3033	 x4 5/16" FLAT WASHER	PT # 3069	 x2 3/8" - 16 x 3/4" FLANGE BOLT	PT # 1154	 x4 3/8" - 16 x 2.5" CARRIAGE BOLT
PT # 3067	 x24 3/8" - 16 FLANGE LOCK NUT	PT # 3032	 x2 INFLATION VALVE AND VALVE CAP ASSEMBLY	PT # 9036	 x6 RED NYLON TIE
PT # 3150	 x2 3/8" - 16 x 2" FLANGE BOLT	PT # 3376	 x4 3/8" - 16 x 5" CARRIAGE BOLT	PT # 0899	 x2 THERMAL SLEEVE

# CONTENTS AND OVERVIEW

PAGE 4 REMOVE EXISTING JOUNCE BUMPER

PAGE 5 PRE-ASSEMBLE AIR SPRING ASSEMBLY

PAGE 6 INSTALL LOWER BRACKET

PAGE 7 BEGIN INSTALLING AIR SPRING ASSEMBLY

PAGE 8 FINISH INSTALLING AIR SPRING ASSEMBLY

PAGE 9 SECURE LOWER BRACKET

PAGE 10 AIR LINE TUBE & INFLATION VALVE INSTALLATION

PAGE 11 INSTALL & ROUTE AIR LINE TUBE

PAGE 12 CHECKING THE SYSTEM

PAGE 13 FIXING AN AIR LEAK

PAGE 14 FINISHING THE INSTALLATION

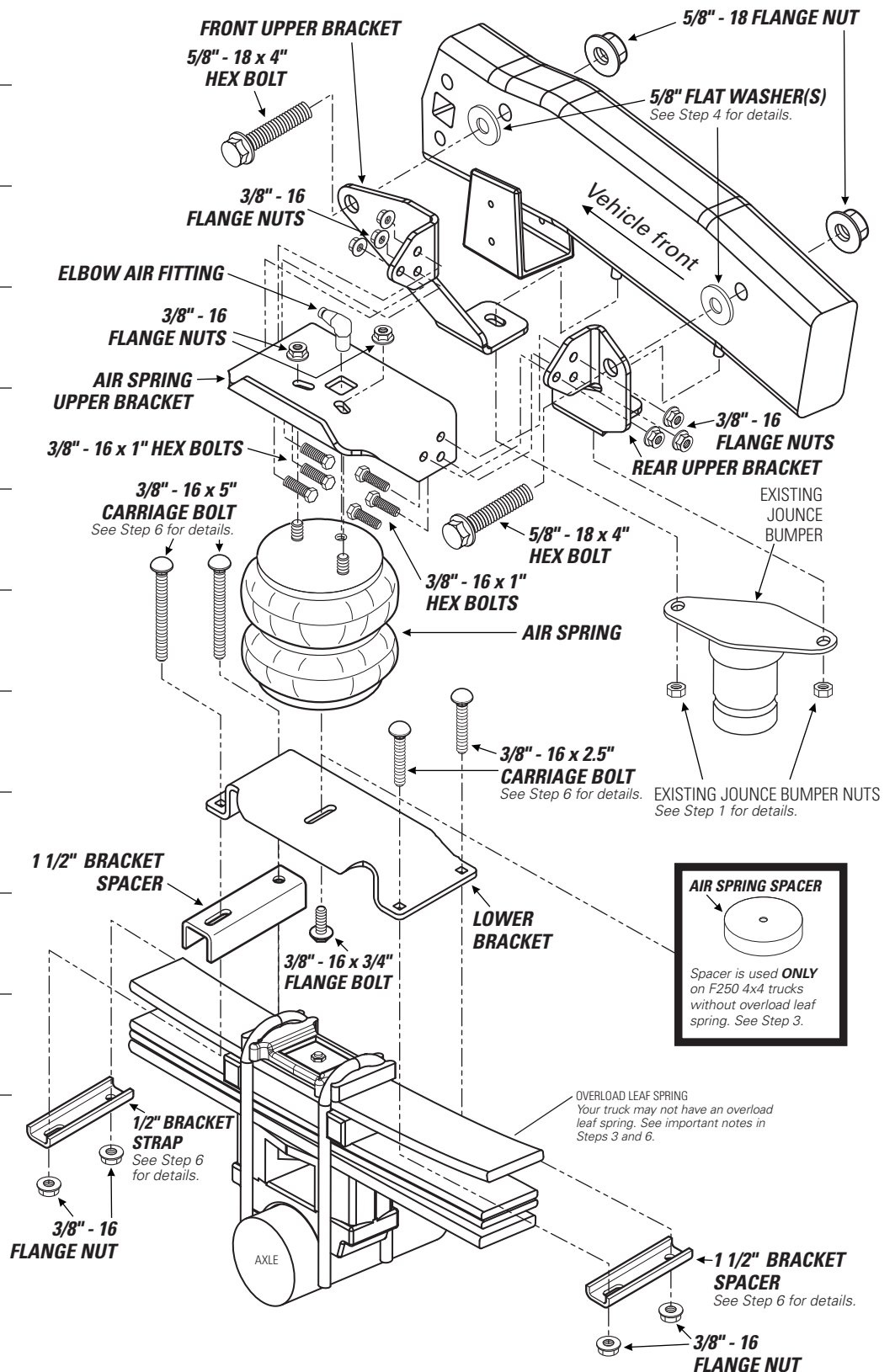



**1** Remove the existing Jounce Bumper and nuts. KEEP THESE ITEMS. THEY WILL BE USED LATER IN THE INSTALLATION.



START THE INSTALLATION ON THE LEFT SIDE OF THE VEHICLE WHEN FACING FORWARD.

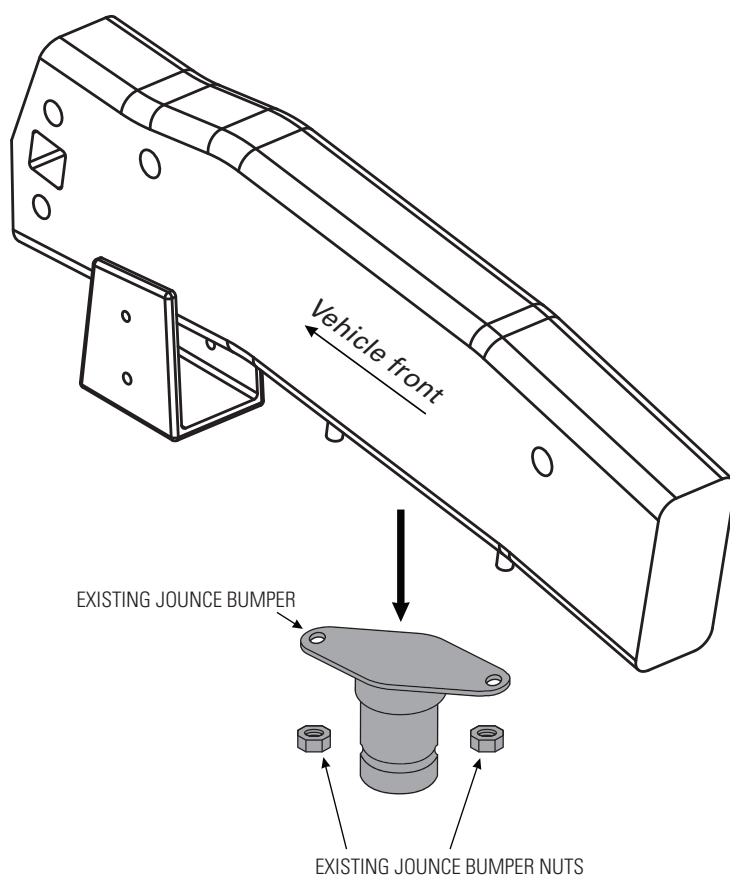

# 2

## PRE-ASSEMBLE AIR SPRING ASSEMBLY

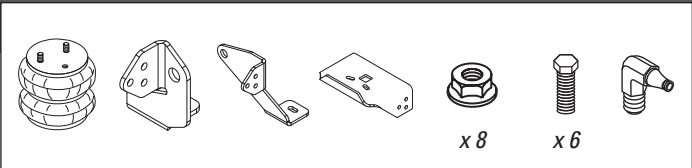

Leave this nut loose to allow room for the 5/8" - 18 x 4" bolt in Step 4.

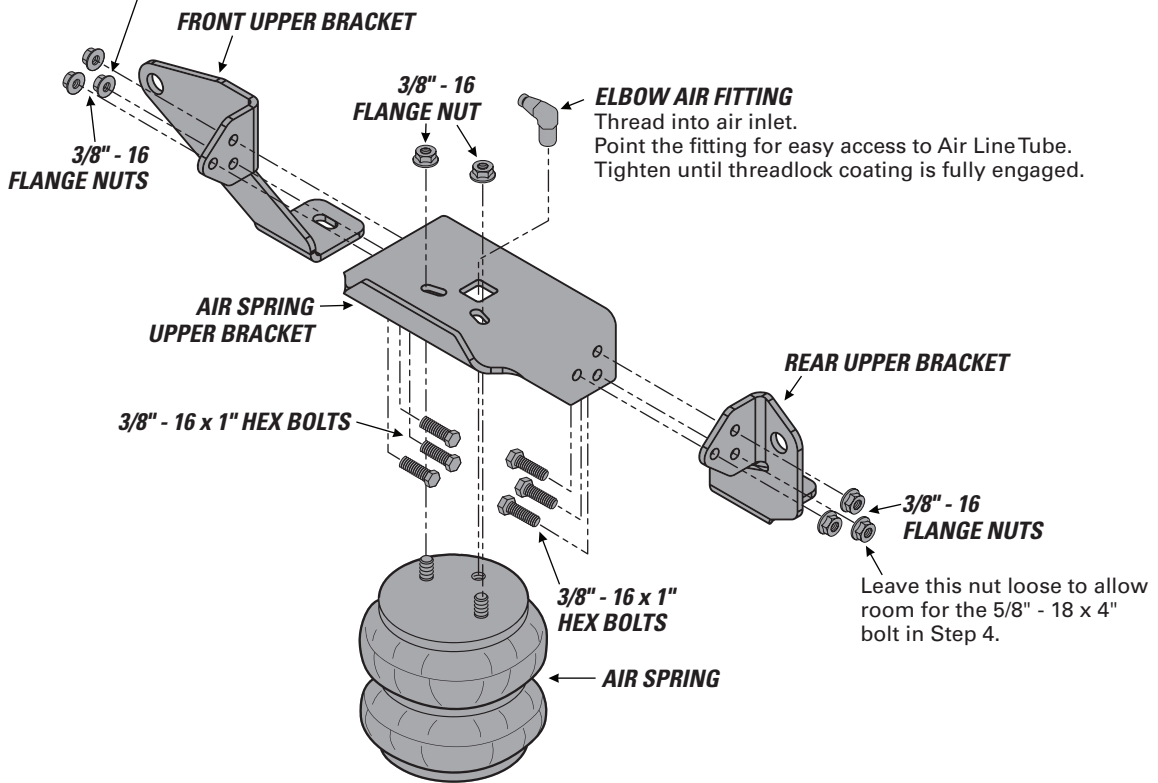

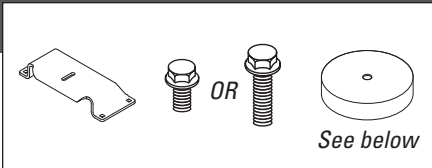

**AIR SPRING AND UPPER BRACKETS**

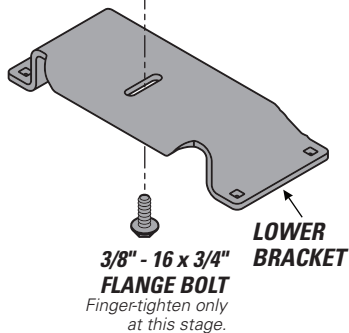
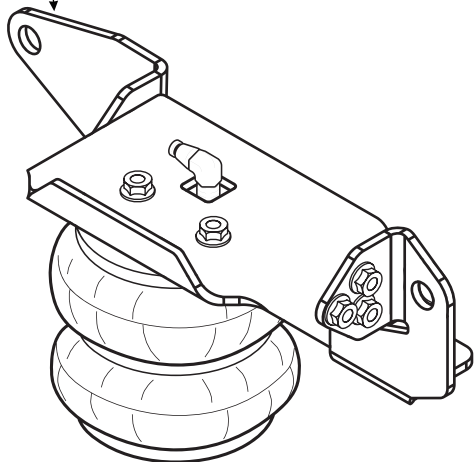

**F250 4X4 TRUCKS WITHOUT OVERLOAD LEAF SPRING.**

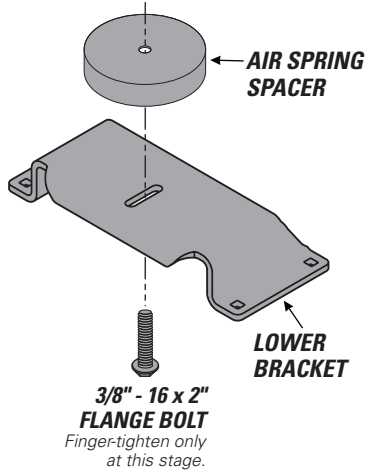

**WITHOUT OVERLOAD LEAF SPRING.**

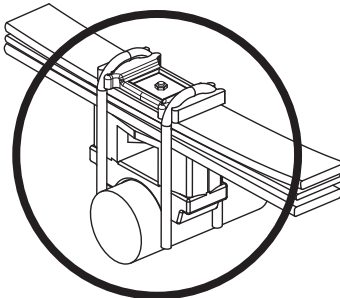

**WITH OVERLOAD LEAF SPRING.**

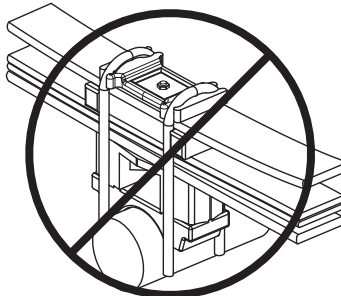

# 4

## BEGIN INSTALLING AIR SPRING ASSEMBLY

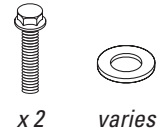

**1** Fit the Air Spring Assembly into place as shown, using the 5/8" - 18 x 4" Flange Bolts to hold the assembly in place. Note the washer requirements.

**2** Reinstall the existing Jounce Bumper and hardware below the Upper Bracket lower flanges. Fully-tighten the two fasteners.

**3** Fully-tighten the 2 bottom 3/8" - 16 Flange Nuts on either side of the Upper Brackets.

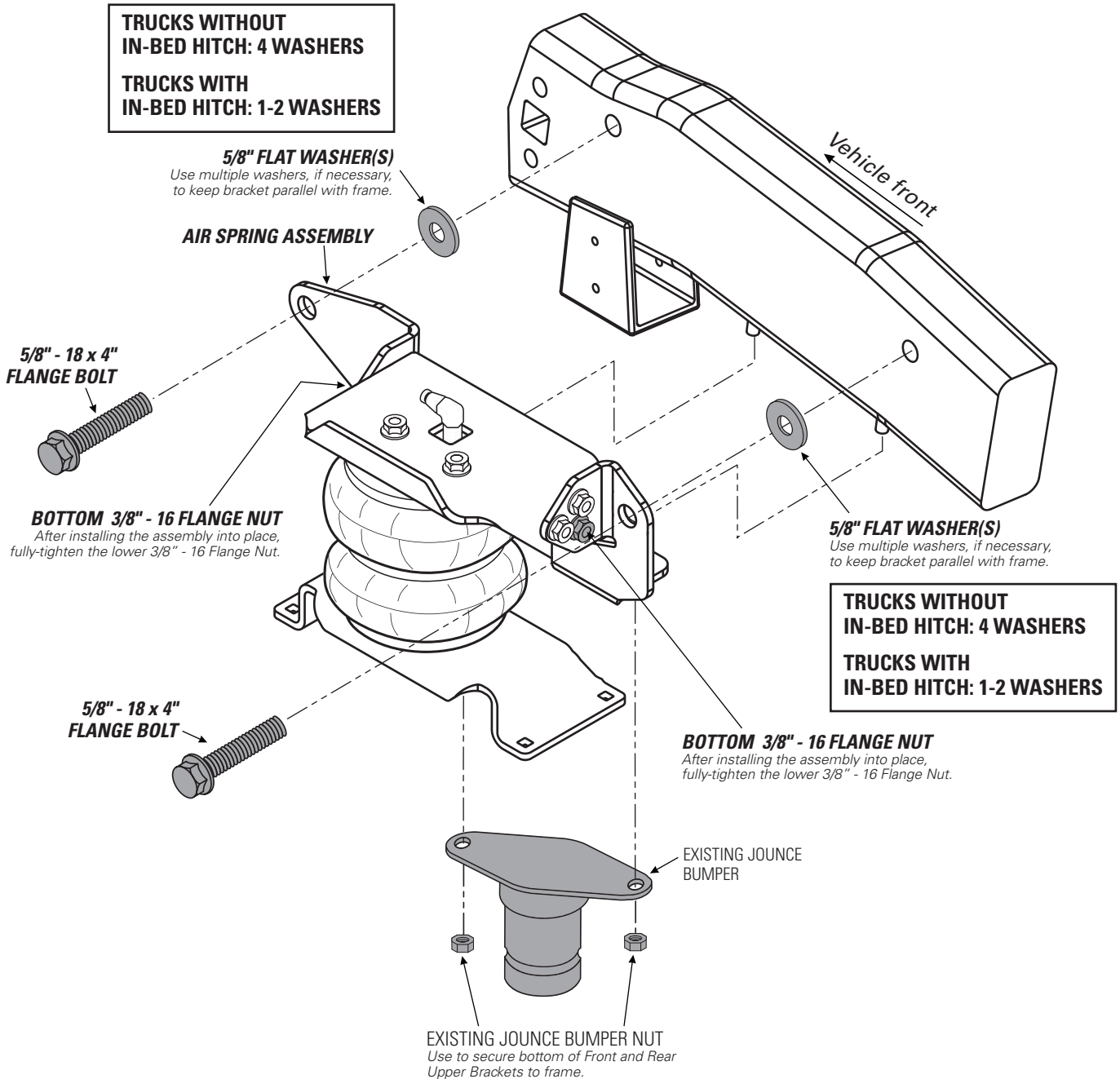



x2

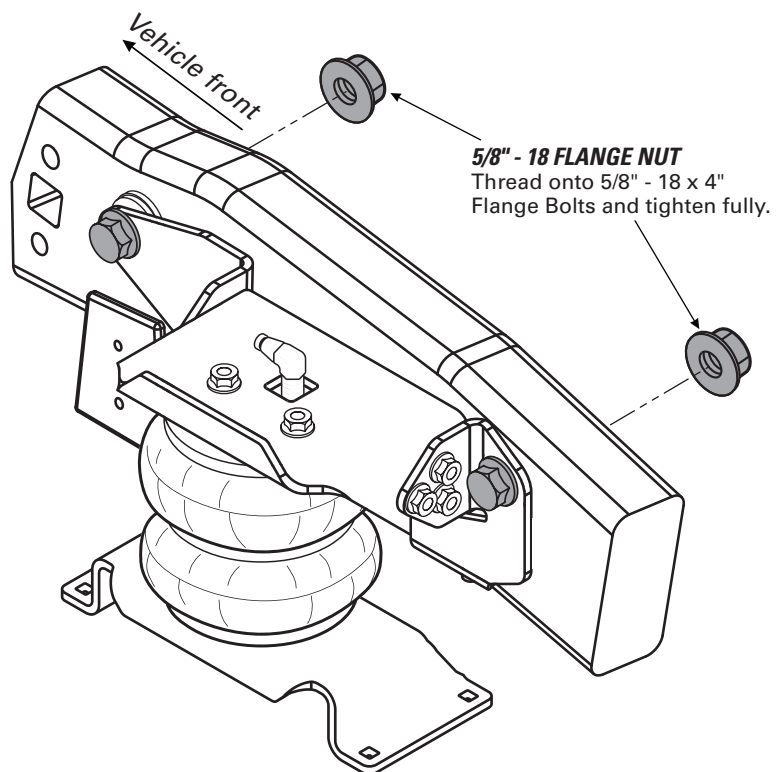

# 6

## SECURE LOWER BRACKET

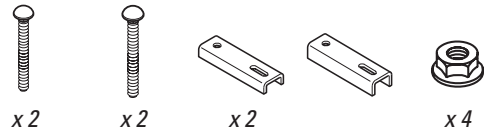

**1** Follow guidelines below to dry fit assembly. Make alignment marks as shown.

**2** Match alignment marks you made, then **fully tighten the 3/8\" - 16 Flange Bolt to the Air Spring.**

**3** Install the remaining items, as shown. See notes on Carriage Bolt selection.

**3/8\" - 16 x 5\" CARRIAGE BOLT**  
For use when an overload leaf spring is present. If your truck does not have an overload leaf spring, use the 3/8\" - 16 x 6\" Carriage Bolts.



USE YOUR HAND TO CHECK FOR THE PROPER CLEARANCE AROUND THE AIR SPRING. IF YOUR HAND DOES NOT FIT BETWEEN THE AIR SPRING AND OTHER COMPONENTS, IT WILL RUB!

**3/8\" - 16 x 2.5\" CARRIAGE BOLT**  
For use when an overload leaf spring is present. If your truck does not have an overload leaf spring, use the 3/8\" - 16 x 5\" Carriage Bolts.

**1 1/2\" BRACKET SPACER**  
Not used on 2VVD trucks.

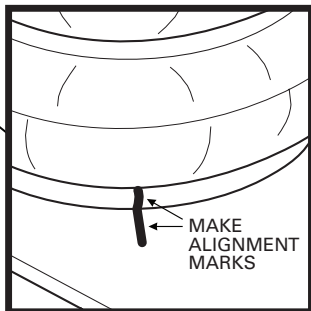

**1/2\" BRACKET STRAP**  
If no overload leaf spring is present, use below leaf stack.

**3/8\" - 16 FLANGE NUT**  
May require using open-ended 9/16\" wrench.

**1 1/2\" BRACKET SPACER**  
If no overload leaf spring is present, use below leaf stack.

**3/8\" - 16 FLANGE NUT**  
May require using open-ended 9/16\" wrench.



**AWESOME!** You're done with the left side. Go back to Step 1 and repeat the steps for the right side installation.



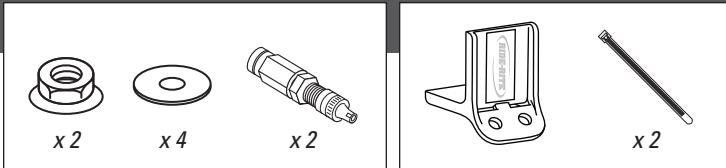

IF USING THE OPTIONAL NO-DRILL INFLATION VALVE BRACKET, CHOOSE OPTION 1. IF DRILLING, CHOOSE OPTION 2. **INFLATION VALVES MUST BE ACCESSIBLE BY AN AIR CHUCK.**

**1** Secure the Air Inflation Valve Bracket to a protected, secure location. **PROCEED TO STEP 3.**

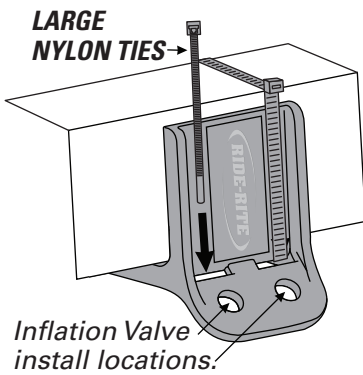

**2** Select a protected location to install the Inflation Valves, such as the bumper or the body of the vehicle.

Drill two 5/16" holes for Inflation Valve install locations.

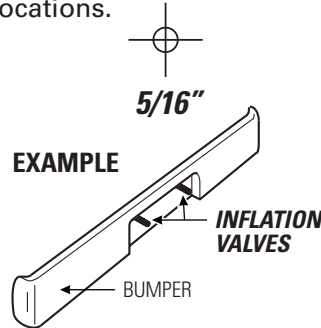

**3** Install Inflation Valve assembly as shown.

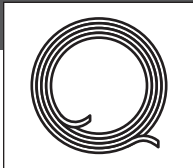
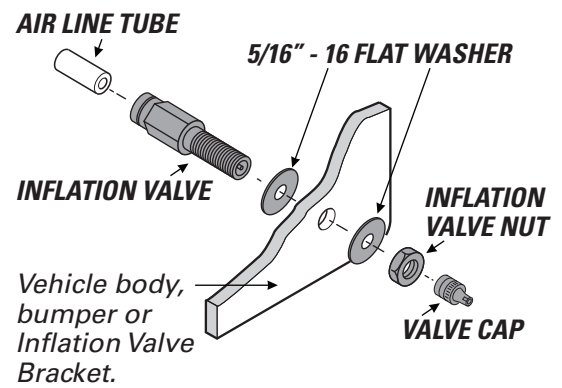

**1** Match Air Line Tube ends.

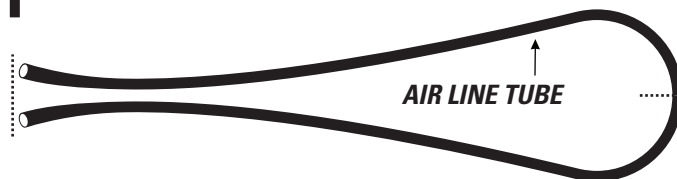

**2** Find center of Air Line Tube, make a square cut with tube cutter or sharp utility knife.

**DO**

Make sure the cut is as square as possible. Use a tube cutter or sharp utility knife.

**DON'T**

Fold or kink the Air Line Tube. Cut the Air Line Tube at an angle. Use pliers, scissors, snips, saws, or side cutters.

**PROPER AND IMPROPER CUTS IN THE AIR LINE TUBE**

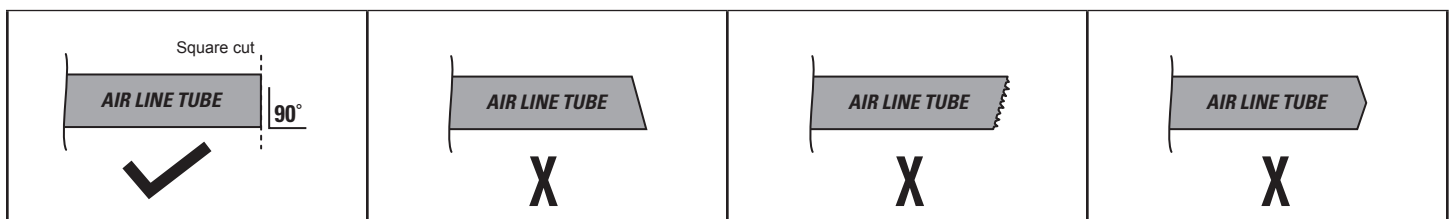

# 9

## INSTALLING AIR LINE TUBE INTO AIR FITTINGS AND INFLATION VALVE

**1** Insert end of Air Line Tube into Air Fitting.

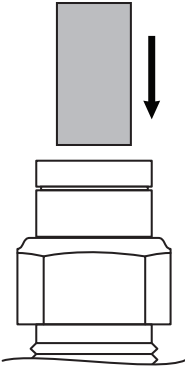

**2** Push Air Line Tube into Air Fitting as far as possible.

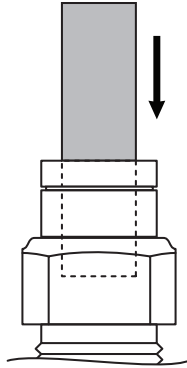

**3** Gently pull on the Air Line Tube to check for a secure fit.

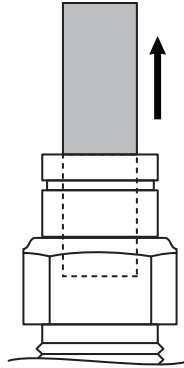

**4** To remove, push down collar and gently pull Air Line Tube away.

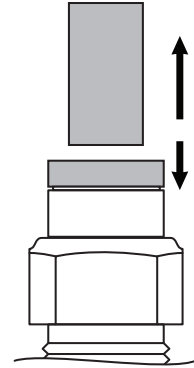

**Removal Tip:** Use a 1/4", 5/16", or 6mm open-ended wrench to push the collar down.

# 10

## ROUTE AND SECURE AIR LINE TUBES

Air Line Tube routes will vary, depending on your truck, and requires you to choose the best path from the Air Springs to the Inflation Valves. Use the instructions below to help you choose.

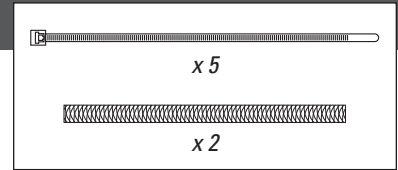

# DO

Select routes protected from heat, debris, and sharp edges. Use Thermal Shields near heat sources. Use Nylon Ties to secure the Air Line Tube.

# DON'T

Bend or sharply curve Air Line Tubes. Leave Air Line Tube exposed to sharp edges. Use unnecessary lengths of Air Line Tube. Route Air Line Tube near moving parts. Let Air Line tube hang unsecured from vehicle. Scar Air Line Tube while routing.

AIR LINE TUBE      THERMAL SHIELD

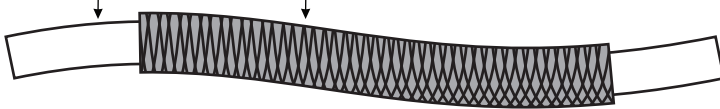

USE SUPPLIED THERMAL SHIELDS WHEN AIR LINE TUBE RUNS **WITHIN 6 INCHES** OF HEAT SOURCES.

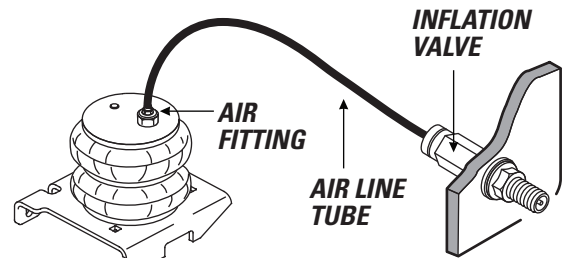

- 1** Place an air chuck onto the Inflation Valve and fill the system to **70 PSI**.

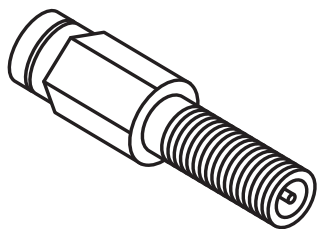

AIR SPRINGS INFLATE QUICKLY. CHECK AIR PRESSURE WHILE INFLATING.

- 2** Spray fittings with soap and water mixture.



- 3** Observe bubbles.

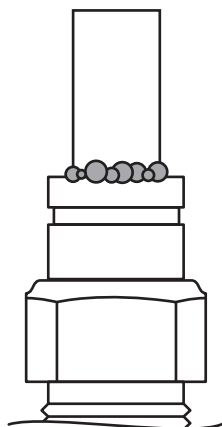

**SMALL SOAP BUBBLES  
THAT DO NOT EXPAND**

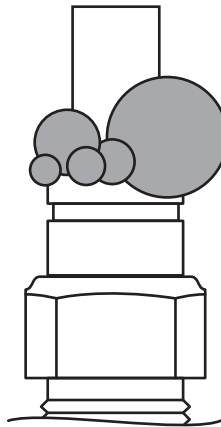

**SOAP BUBBLES  
THAT EXPAND**



# NO LEAKS?

Congratulations! Continue to Step 13 to finish installation. Review the Operating Instructions.

# LEAK?

Bummer. Continue to Step 12 to fix the leak.

# 12

## FIXING AN AIR LEAK

- 1 Press the air valve on end of Inflation Valve to release all air pressure.

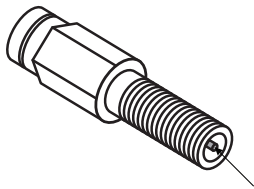

AIR VALVE



EXHAUST ALL AIR FROM THE SYSTEM PRIOR TO RELEASING AIR LINE TUBES FROM AIR FITTINGS.

### LEAK AT AIR LINE TUBE AND AIR FITTING

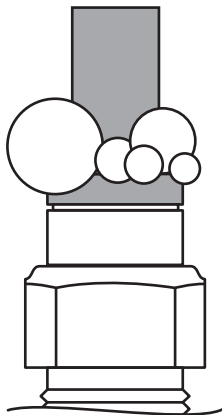

Release Air Line Tube (see page 11). Review proper cuts and procedures in Step 8. Repeat Steps 9 and 11.

### LEAK AT BASE OF AIR FITTING ON AIR SPRING

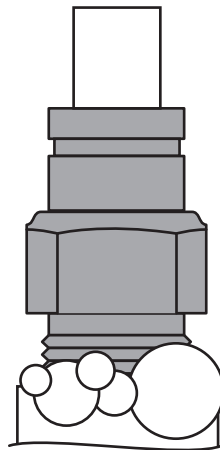

Tighten Air Fitting one turn or until leak stops.

### LEAK OUT OF THE VALVE CORE ON INFLATION VALVE

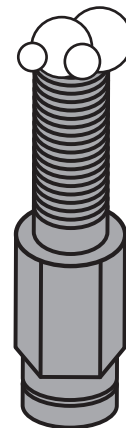

Tighten valve core with valve core wrench on Inflation Valve Cap.

# STILL HAVE A LEAK?

Refer to the Troubleshooting section of the Instruction Manual. If the leak persists, or if there is an issue with a leaking part, call 1-800-888-0650; Option 1; Option 1 for Tech Support.

**SAFELY RETURN VEHICLE TO OPERATIVE STATE**

If you removed any wheels during installation, install the wheels and torque the lug nuts to the manufacturer's specifications.

Safely remove any jack stands and wheel chocks used during installation.

Re-attach the negative battery cable.

**DOUBLE-CHECK AIR SPRING CLEARANCE**

Check the Air Springs once again for the proper 1/2" minimum clearance. Perform clearance check again when vehicle is under load.

**VEHICLE GVWR**

NEVER exceed the maximum load recommended by the vehicle manufacturer (GVWR). The GVWR can be found in your vehicle's owner's manual or on the data plate on the driver's side door. Consult your local dealership for additional GVWR specifications.

**READ AND UNDERSTAND THE OPERATING INSTRUCTIONS**

The Ride-Rite system can improve handling and comfort. Take the time to learn how to properly use and maintain your investment by reading the Operating Instructions.



USE YOUR HAND TO CHECK FOR THE PROPER CLEARANCE AROUND THE AIR SPRING. IF YOUR HAND DOES NOT FIT BETWEEN THE AIR SPRING AND OTHER COMPONENTS, IT WILL RUB!

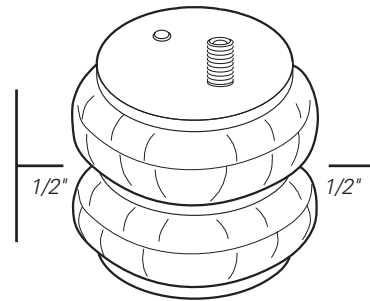

# ! IMPORTANT

**A MINIMUM OF 5 PSI MUST BE MAINTAINED IN THE AIR SPRINGS AT ALL TIMES**

Too much air pressure in the Air Springs will result in a firmer ride, while too little air pressure will allow the Air Springs to bottom out over rough conditions, and will not provide the improvement in handling that is possible.



MINIMUM PRESSURE



MAXIMUM PRESSURE (LOADED)



[riderite.com](http://riderite.com)

## BEFORE YOU DRIVE, CONFIRM THE FOLLOWING:

- Do you have a minimum of 5PSI in your Air Springs?
- Are your Air Springs standing 5 1/2" - 6 1/2" tall? 5 1/2" - 6 1/2"
- Are your Air Springs properly aligned, left-to-right and front-to-back?
- Are your nuts and bolts tight?
- Put your paper work back into the sleeve and keep it in your glove compartment for future reference.
- You've been bagged...and now your suspension is Airide™ equipped! Show it off with the supplied decal!

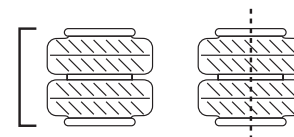

## NEED INSTALLATION HELP? 1-800-888-0650

Select Option 1 for Ride-Rite; Select Option 1 for Technical Support.

Or, email us at [rrtech@fsip.com](mailto:rrtech@fsip.com). If emailing, please include photos to help us better diagnose and understand any problems you may be experiencing.



CONNECT WITH US



@rideriteair



@rideriteair



Firestone RideRite



Firestone Ride-Rite