

# PART#: 75-5157 / 75-5157D



PRINT

## Vehicle Application

YEAR: 1999-2007

MAKE: Chevy / GMC / Cadillac

MODEL: Silverado 1500 2500, 3500, Sierra 1500 2500 3500, Avalanche, Escalade

ENGINE: 4.8L, 5.3L, 6.0L, 6.2L

YEAR: 2007-2008

MAKE: Chevy / GMC

MODEL: Tahoe, Yukon

ENGINE: 4.8L, 5.3L

### Note:

This intake kit may not fit with the following Aftermarket Parts installed:

- Body Lift or Lowering Kit
- Custom Hood
- Throttle Body Spacer / Upgrade

## Tools Required

Ratchet and extensions

10mm socket and wrench

5/16" socket and wrench/nut driver or flat head screwdriver

Phillips screwdriver

9/16" or adjustable wrench

**Note:** Approximate Install Time: 1 Hr 00 Mins.

## S&B Filter Maintenance

KF-1063 ([https://www.sbfilters.com/replacement-filters/filters-sb-intakes/kf-1063?variant\\_id=211](https://www.sbfilters.com/replacement-filters/filters-sb-intakes/kf-1063?variant_id=211)) Cotton Cleanable : If the enclosed filter is RED, it came pre-oiled from the factory.

Click here ([https://www.sbfilters.com/replacement-filters/filters-sb-intakes/kf-1063?variant\\_id=211](https://www.sbfilters.com/replacement-filters/filters-sb-intakes/kf-1063?variant_id=211)) for exact oil amount required for cleaning.

KF-1063D ([https://www.sbfilters.com/replacement-filters/filters-sb-intakes/kf-1063?variant\\_id=212](https://www.sbfilters.com/replacement-filters/filters-sb-intakes/kf-1063?variant_id=212)) Dry Extendable : If the enclosed filters is WHITE, it is a disposable filter and should be discarded once it reaches capacity. This filter does not require oil.

## **Warning**

If your vehicle has a Vehicle Emission Control Information decal affixed to the factory airbox, a new replacement label must be obtained and installed in a readily visible position in the engine compartment in order to remain CARB compliant. Failure to do so will prevent the vehicle from passing a smog check. Replacement labels can be ordered from your local dealership. Regulations state that the VECI label shall not be affixed to any equipment which is easily detached from the vehicle. Label placement, under the hood on a painted surface, is recommended.

## **Before You Start**

- Please read the entire product guide before proceeding.
- Ensure all parts are present.
- If you are missing any of the components, call our customer support at (909) 947-0015.
- Do not work on your vehicle while the engine is hot.
- Make sure the engine is turned off and the vehicle is in Park or the Parking Brake is set.

## **Related Products**

- Cotton Cleanable Filter ( KF-1063 ([https://www.sbfilters.com/replacement-filters/filters-sb-intakes/kf-1063?variant\\_id=211](https://www.sbfilters.com/replacement-filters/filters-sb-intakes/kf-1063?variant_id=211)))
- Dry Extendable Filter ( KF-1063D ([https://www.sbfilters.com/replacement-filters/filters-sb-intakes/kf-1063?variant\\_id=212](https://www.sbfilters.com/replacement-filters/filters-sb-intakes/kf-1063?variant_id=212)))
- Cleaning & Oiling Kit (88-0008 (<https://www.sbfilters.com/cleaning-kits/precision-ii-cleaning-oil-kit>))
- Air Filter Wrap (WF-1059 (<https://www.sbfilters.com/filter-wraps/wf-1059>))

## **Air Box Plug Testing**

Stock air boxes are a significant contributor to poor airflow which is why S&B designs custom air boxes with secondary and/or enlarged openings. With that said, S&B recognizes the benefits of cooler air. For optimal performance, we recommend that the intake be used without the end cap except in conditions of extreme heat.

## **Performance Testing**

- After your installation is complete engage parking brake and start your engine. Listen for abnormal noises. If an air leak is detected, re-inspect hoses and connections as they may need to be repositioned and tightened
- S&B FILTERS recommends that you keep your OE intake system in the event it is required in the future.
- In order to maintain your warranty, all connections and components must be checked periodically for alignment and for proper tension on all connections. Failure to do so may void your warranty.
- Use only S&B FILTERS cleaning and oil products to service your filter. Using any other brand oil and or cleaners on your S&B air filter may void your warranty.

## **Emission Standard**

The California Air Resource Board (CARB) requires that an E.O. identification label be applied to the vehicle in order to pass a smog check inspection when a Performance Intake Kit has been installed. You must place the E.O. label provided on or near the intake kit after installation so that a smog check technician can easily verify the E.O. number. Check the status of the exemption process by looking up a specific part number at [www.sbfilters.com](http://www.sbfilters.com). The CARB Exemption number and/or status is listed under the Product Details section for each part number. If the status shows as "Pending," CARB has yet to issue an exemption. Products that have not been issued an EO number are street legal in most states, but may not be used on emission controlled vehicles in the state of California and are for off-road use only. If you purchased your kit from S&B Filters directly, we will automatically mail you your Exemption Sticker when it is issued to us. If you purchased your kit from an authorized S&B Filters Dealer, log onto our web site and register to receive your Exemption Sticker.

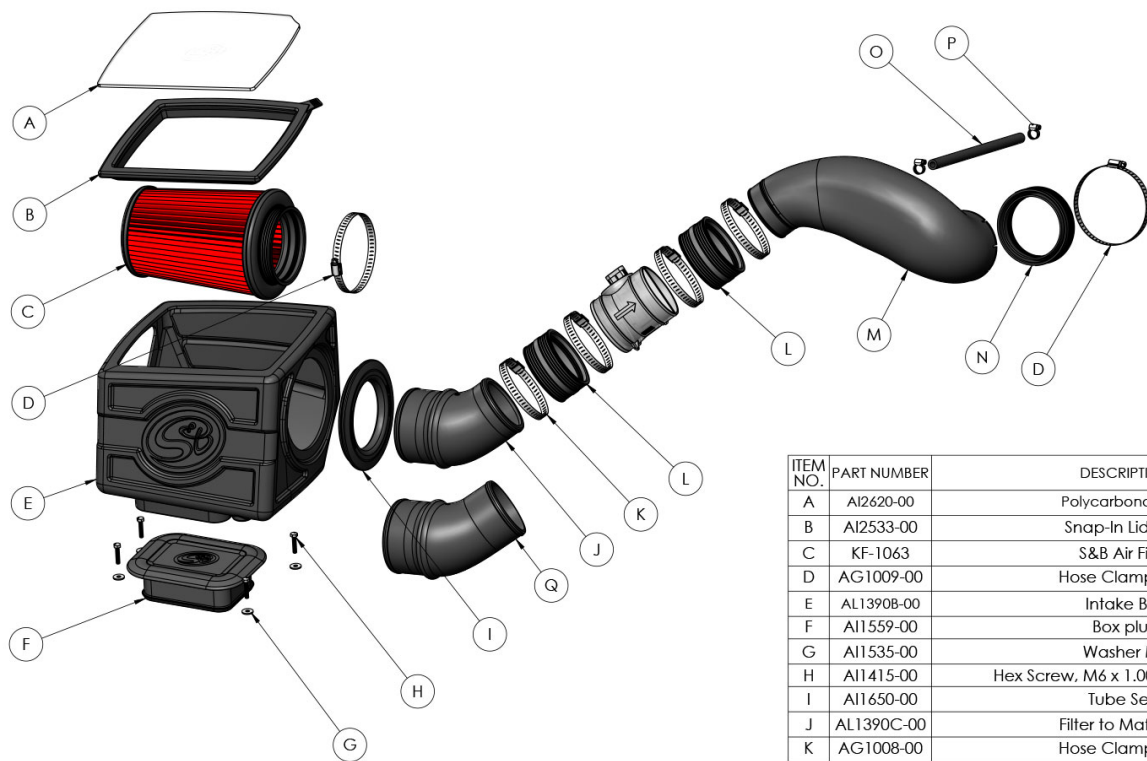

ITEM NO.	PART NUMBER	DESCRIPTION	QTY.
A	AL2620-00	Polycarbonate Lid	1
B	AL2533-00	Snap-In Lid Seal	1
C	KF-1063	S&B Air Filter	1
D	AG1009-00	Hose Clamp, #72	2
E	AL1390B-00	Intake Box	1
F	AL1559-00	Box plug	1
G	AL1535-00	Washer M6	4
H	AL1415-00	Hex Screw, M6 x 1.00 mm x 30 mm	4
I	AL1650-00	Tube Seal	1
J	AL1390C-00	Filter to Maf Tube	1
K	AG1008-00	Hose Clamp, #50	4
L	AL1129C-00	Straight Coupler	2
M	AL1390C-00	Intake Tube	1
N	AL1097C-00	Silicone Coupler	1
O	AL1037-00	Silicone Hose, 3/8" x 13" Long	1
P	AG1021-00	Hose Clamp, #4	2
Q	AL1390-00	Filter to Maf Tube 2	1

## INSTALLATION STEPS



## STEP 1

With the ignition switched off and the parking brake set, disconnect the negative battery cable on the battery.

---

**IMPORTANT:** Failure to disconnect the battery for a minimum of 2 hours may cause the Check Engine Light to illuminate upon completion of the installation or subsequent operation.

**DO NOT SKIP THIS STEP!**

---



## STEP 2

If equipped: Loosen the retaining bolt and pull up and out to remove the engine cover from the Vehicle.



### **STEP 3**

Disconnect the electrical connection to the MAF sensor.



#### **STEP 4**

If equipped, pull the crankcase vent line from the OE tube and then from the engine along with the rubber connector and remove it from the vehicle.



#### **STEP 5**

Carefully pry the hose router clamp from the OE air intake tube.



## **STEP 6**

Loosen the hose clamp at the throttle body and at the MAF sensor.





## **STEP 7**

Pull the OE air box towards the engine and up to release it from the vehicle.



## STEP 8

Loosen the hose clamp on the OE airbox and remove the MAF sensor. Note the direction of the airflow through the sensor.

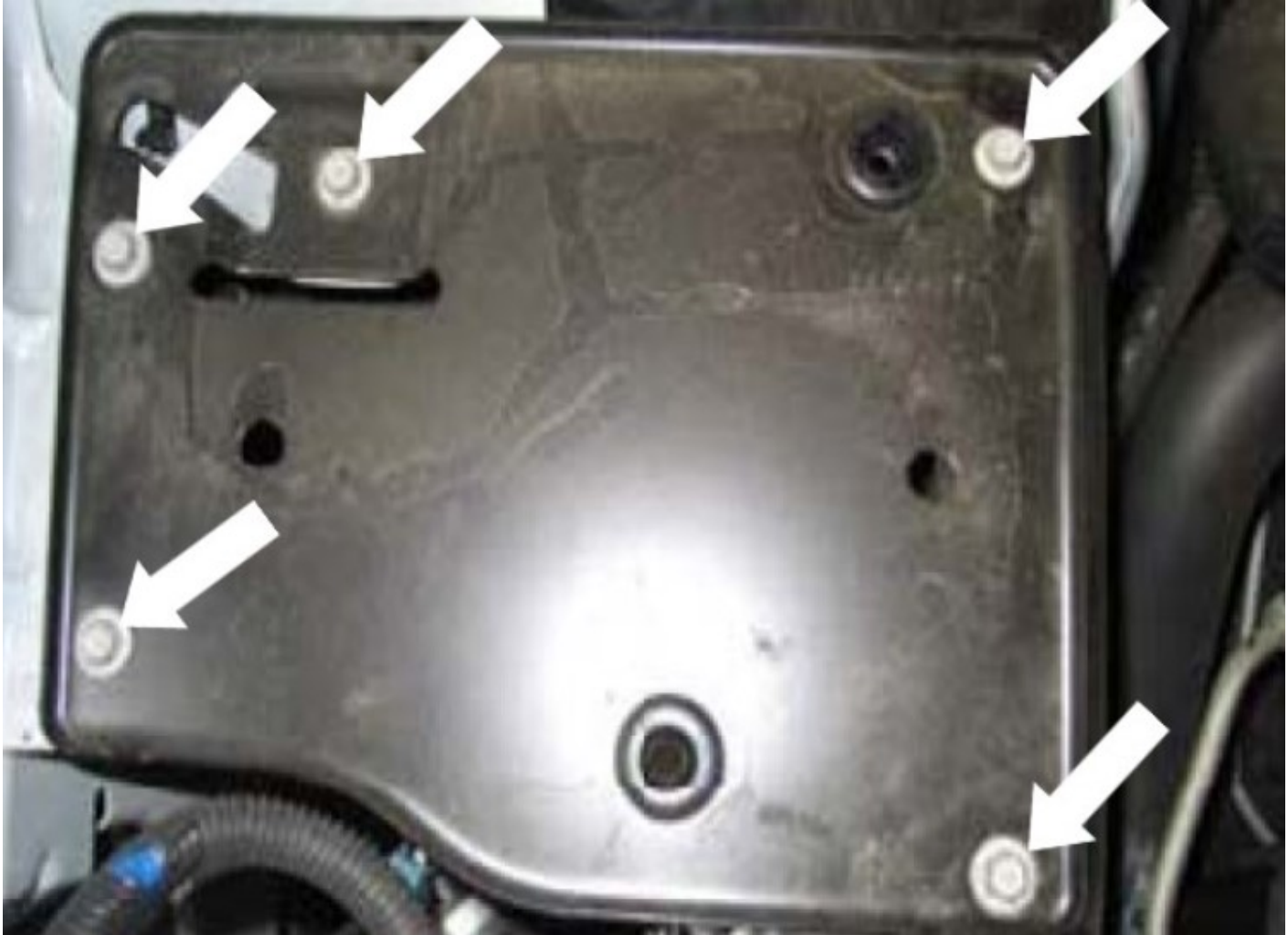

## STEP 9

Remove the OE tray from the vehicle. Four of these bolts (if long enough), can be used to secure the S&B airbox to the vehicle. IF too short, then use the supplied Allen head screws (H) and ss washers (G).



## **STEP 10**

Install Box Seal (I) to the S&B intake Air Box (E). Make sure that the Air Box (E) is fully seated into the groove of Box Seal (I).



## **STEP 11**

Determine if you want to install the Air Box Plug(F).



## **STEP 12**

Identify the correct Filter to MAF tube for your vehicle:

**Note: Filter to MAF tube AL1390C-00 (J):**

2007-2008 Tahoe, Yukon, Avalanche and Cadillac Escalade

**Filter to MAF tube #2 AL1390-00 (Q) :**

1999-2007 Silverado / Sierra 1500, 2500, 3500, Tahoe, Yukon

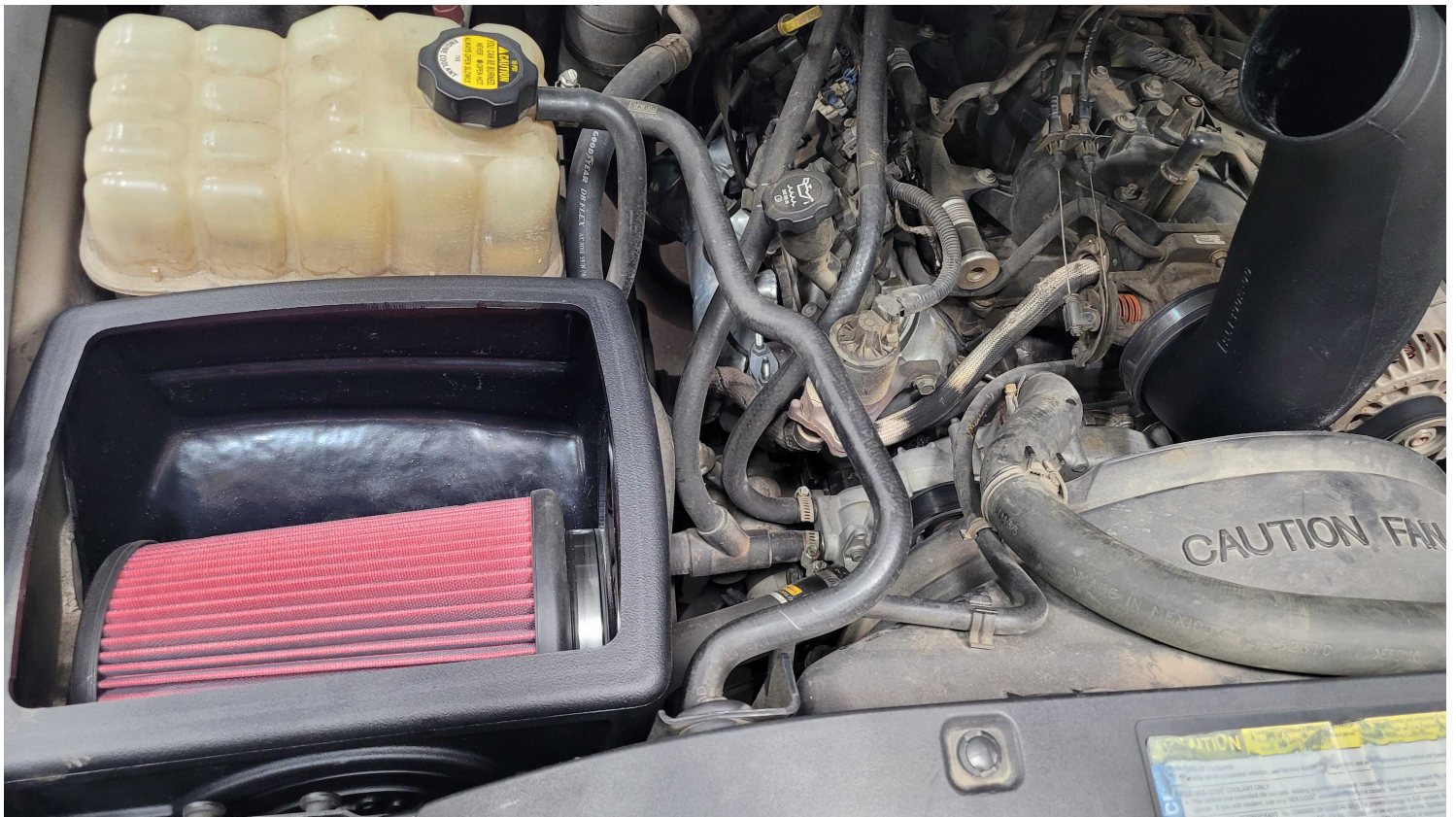

## STEP 13

Work the Air Box (E) into the Vehicle. Align the four holes with the OE Mounting location and secure using OE bolts or supplied Allen head screws (H) and ss washers(G). Place S&B Filter (c ) inside of Air Box (E).



## **STEP 14**

Slide the S&B straight coupler (L) over the MAF sensor's honeycomb end, secure using a # 50 Hose Clamp (K).



## **STEP 15**

Connect the MAF sensor Assembly (Step 15) to the Filter to MAF Tube (J or Q) and secure using a #50 Hose Clamp (K).





## **STEP 16**

Install the S&B Air Filter (c ) and #72 Hose Clamp (D) onto the Filter to MAF Tube (J or Q). Insert the Filter to MAF Tube(J or Q) fully into the S&B Air Filter (c ) until it stops on the Filter flange shoulder. The Filter flange should line up with the bead on the tube.





## **STEP 17**

Align the Air Box (E) and Filter to MAF tube (J or Q) with the location arrow.



## **STEP 18**

Slide the Silicone Coupler (N) over the Intake Tube (M) throttle location along with the #73 Hose Clamp (D), do not fully tighten at this time.



## STEP 19

Slide the Straight Coupler (L) over the Intake Tube (M) MAF sensor location along with the #50 Hose Clamp (K), do not fully tighten at this time.



## STEP 20

Position the Silicon Coupler (N) end of the over the throttle body and firmly secure the #72 Hose Clamp (D), then secure the # 50 Hose Clamp (K) at the Straight Coupler.



## STEP 21

Install the Silicone Hose (O) onto the Intake Tube (M) inlet port and then onto the engine port where the OE line was removed in Step 5. Secure the silicone hose with two #4 Hose Clamps (P).



## **STEP 22**

Peel off the protective covering on the Polycarbonate Lid (A). Do not forget to remove the protective covering around the S&B logo.



## **STEP 23**

Install the Snap-In Lid Seal (B) around the outside edge of the Polycarbonate Lid (A).



## **STEP 24**

Install the polycarbonate Lid (A) with Snap-In Lid Seal (B) onto the Intake Box (E). start by inserting the Lid seal groove over the Air box opening on one corner first and then work your way around the Air Box. Make sure that the Lid seal groove snaps over the entire Air Box opening. Check all around the Lid seal snap groove to make sure it has snapped over the entire Air Box opening.





## **STEP 25**

Reconnect the MAF harness to the MAF sensor.



## **STEP 26**

After the batteries have been disconnected for at least 2 hours, reconnect the positive battery terminal on the passenger side first then reconnect the negative terminals.

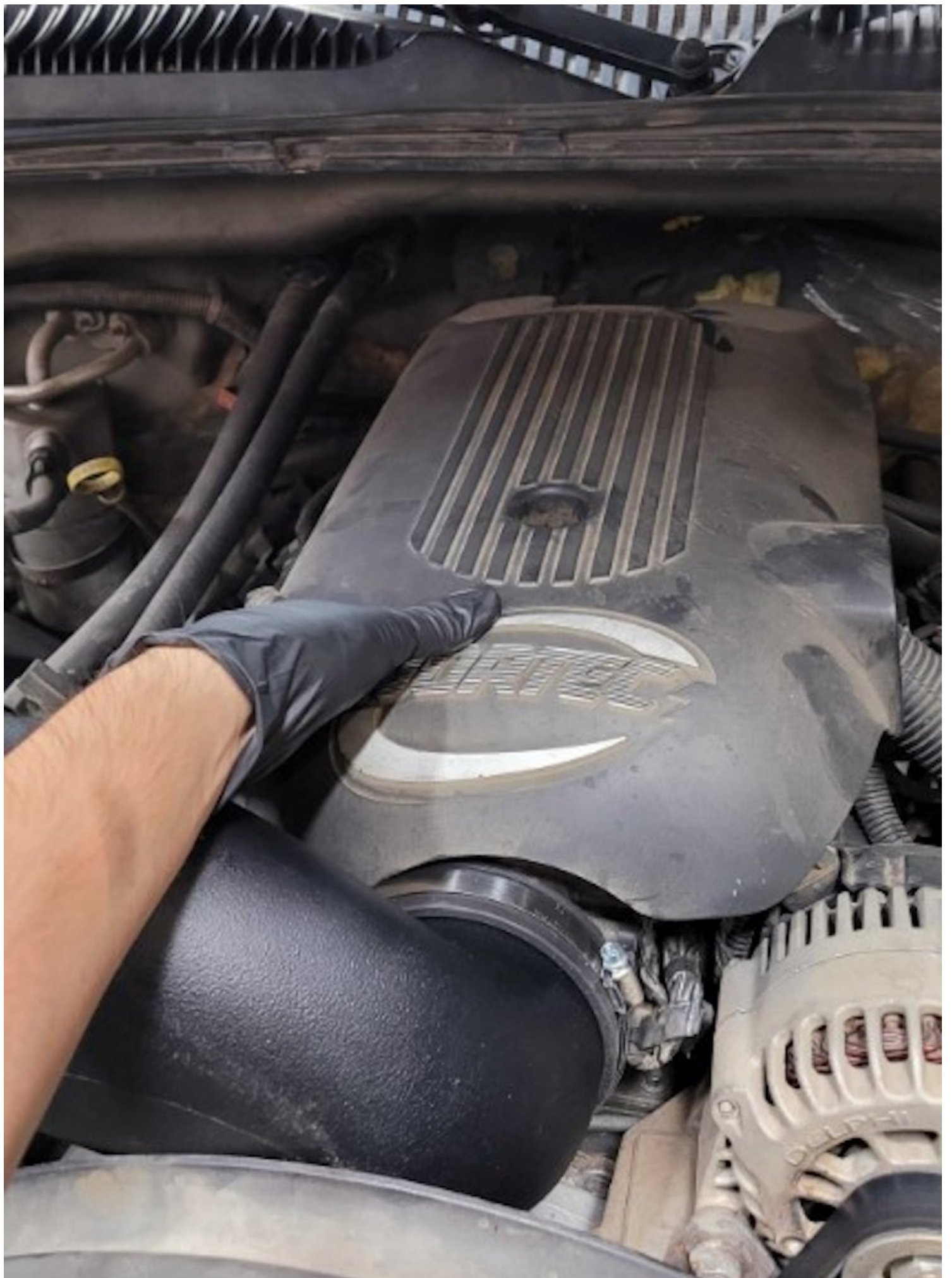

## STEP 27

Install the engine cover.



## STEP 28

Inspect your installation, make sure the kit is properly positioned and all fasteners and hose clamps are secured. Keep all stock parts in case you would ever need to reinstall the stock intake assembly. Affix the ID label near the intake kit. If you are an installer, give the owner the QR code for the installation instructions so that he/she is aware of the maintenance and Operation procedures are given at the beginning of the Instructions. The installation is now complete.