

INSTALL INSTRUCTIONS FOR 75-6002

PART#: 75-6002

Vehicle Application

YEAR: 2020-2022

MAKE: Ford

MODEL: F-250/F-350

ENGINE: 6.7L Powerstroke

Note: Kit may not fit with the following Aftermarket Parts installed:

- Body Lift or Lowering Kit
- Custom Hood
- Throttle Body Spacer / Upgrade

Tools Required

- Socket Wrench
- 7mm, 8mm, 10mm, 13mm Socket and Wrench
- 3/8" Socket Extension
- 5/16" Nut Driver
- Flat Blade Screwdriver or Panel Popper
- T20 Torx Bit
- Phillips Screwdriver
- Scissors

Note: Approximate Install Time: 30 Mins for Kit Installation, 2 Hr 00 Mins for Battery Disconnect

S&B Filter Maintenance

KF-1070 Cotton Cleanable : If the enclosed filter is RED, it came pre-oiled from the factory. [Click here](#) for exact oil amount required for cleaning.

KF-1070D Dry Extendable : If the enclosed filters is WHITE, it is a disposable filter and should be discarded once it reaches capacity. This filter does not require oil, do not wash or oil this filter.

Foam Filter: Service and check the condition of your Foam Filter (J) every time you service your air filter. Wash it with water or gently blow it off with compressed air. If it can't be cleaned with water or compressed air, or it is torn or damaged, please replace the foam filter.

HP1473-00 is the replacement foam kit that includes (1) Foam Filter, (1) Foam Retainer, and (3) Screws.

Periodically Check the Following

- Intake Tube (T) and Filter (AB) connections and Intake Box (A) fasteners making sure they are tight.
- All electrical connections and wire harnesses moved during the installation of the intake and make sure they are secure and away from any hot or moving components.
- Check for any signs of abrasion or wear and tear on the intake tube,

Before You Start

- Please read the entire product guide before proceeding.
- Ensure all parts are present.
- If you are missing any of the components, call our customer support at (909) 947-0015.
- Do not work on your vehicle while the engine is hot.
- Make sure the engine is turned off and the vehicle is in Park or the

Performance Testing

After your installation is complete, engage the parking brake and start your engine. Listen for abnormal noises. If an air leak is detected, re-inspect hoses and connections as they may need to be repositioned and tightened.

S&B FILTERS recommends that you keep your OE intake system in the event it is required in the futur  **Support**

box, filter, and electrical harnesses moved or near the intake and repair/replace as necessary.

Parking Brake is set.

In order to maintain your warranty, all connections and components must be checked periodically for alignment and for proper tension on all connections. Failure to do so may void your warranty.

Use only S&B FILTERS cleaning and oil products to service your filter. Using any other brand oil and or cleaners on your S&B air filter may void your warranty

Air Box Plug Testing

Stock air boxes are a significant contributor to poor airflow which is why S&B designs custom air boxes with secondary and/or enlarged openings. With that said, S&B recognizes the benefits of cooler air, so we have included a plug to seal off the opening if so desired. For optimal performance, we recommend that the intake be used without the plug except in conditions of extreme heat.

Operation in Rain or Snow

If you are driving in heavy snowfall or extreme rain conditions, you should always check for accumulated snow and water on the air filter. The following is recommended after operating the vehicle up to 100 miles in heavy snowfall or extreme rain: At the earliest opportunity, open the hood and check the airbox and filter. If any snow has accumulated, make sure to remove the snow from the filter, box, and inlet. It is ok if the filter is a little wet. Wet filters will normally dry out on their own. If the filter is dripping wet, it should be replaced with another filter that is not wet. Do not reuse the dripping wet filter until it has naturally dried.

Warning!

If your vehicle has a Vehicle Emission Control Information decal affixed to the factory airbox, a new replacement label must be obtained and installed in a readily visible position in the engine compartment in order to remain CARB compliant. Failure to do so will prevent the vehicle from passing a smog check. Replacement labels can be ordered from your local dealership. Regulations state that the VECI label shall not be affixed to any equipment which is easily detached from the vehicle. Label placement, under the hood on a painted surface, is recommended

CARB Status-Pending

Emission Standard

The California Air Resource Board (CARB) requires that an E.O. Identification label be applied to the vehicle in order to pass a smog check inspection when a Performance Intake Kit has been installed. You must place the E.O. Label provided on or near the intake kit after installation so that a smog check technician can easily verify the E.O. Number. Check the status of the exemption process by looking up a specific part number at www.sbfilters.com. The CARB Exemption number and/or status is listed under the Product Details section for each part number. If the status shows as "Pending," CARB has yet to issue an exemption but the product has been submitted. Products that have not been issued an E.O. number are street legal in most states, but may not be used on emission controlled vehicles in the state of California and are for off-road use only. If you purchased your kit from S&B Filters directly, we will automatically mail you your Exemption Sticker when it is issued to us. If you purchased your kit from an authorized S&B Filters Dealer, log onto our web site and register to receive your Exemption Sticker.

EXPLODED VIEW

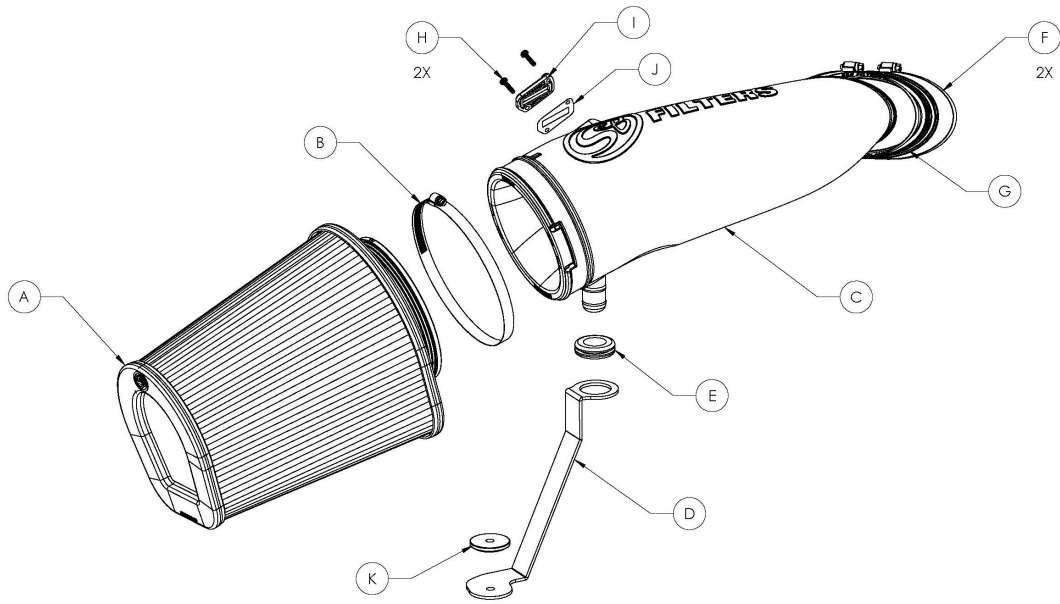

ITEM NO.	PART NUMBER	DESCRIPTION	QTY.	ITEM NO.	PART NUMBER	DESCRIPTION	QTY.
A	KF-1070	Air Filter	1	G	A11523C-00	Straight Coupler	1
B	AG1012-00	Hose Clamp, #104	1	H	A11837-00	8-32 Thread Size, 3/4" Long Screw	2
C	AL1344-00	Intake Tube	1	I	A11822-00	MAF Adapter Pad	1
D	A12476-00	Intake Tube Support Bracket	1	J	A11823-00	MAF Gasket	1
E	A11368-00	Rubber Grommet	1	K	A12494-00	Machined Aluminum Washer	1
F	AG1009-00	Hose Clamp, #72	2				

INSTALLATION STEPS

STEP 1

With the ignition switched off and the parking brake set. Disconnect the negative battery cables on both batteries and the positive battery cable on the passenger side battery.

Note: Failure to disconnect the battery may cause the CEL to illuminate upon completion of the installation and subsequent operation. Do not skip this step!

Tools Required: Socket Wrench, 10mm Socket



STEP 1 (IMAGE 2)



STEP 2

Disengage the white locking clip, press down on the tab, then pull out to disconnect the MAF sensor harness from the MAF sensor.



STEP 3

Remove the ribbed push in clip on the wiring harness from the stock intake lid.

Tools Required: Panel Popper or Flat Blade Screwdriver



STEP 4

Loosen the hose clamps on the intake tube connected to the turbo inlet and intake box.

Tools Required: 7mm Socket/Wrench or Flat Blade Screwdriver

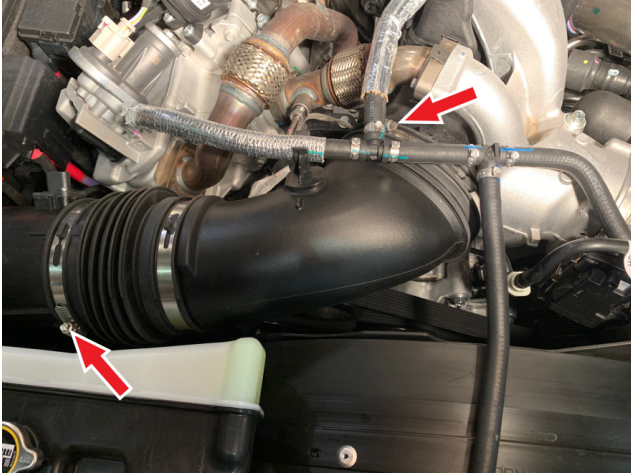

STEP 5

Remove the coolant line from the intake tube clip then remove the intake tube from the vehicle.

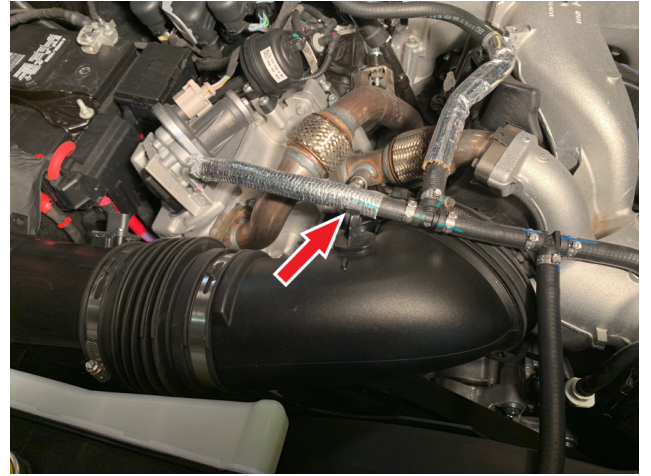

STEP 6

Pop-out the stem and remove the push in rivet securing the stock front inlet.

Tools Required: Panel Popper or Flat Blade Screwdriver



STEP 7

Wiggle the stock front inlet loose and lift up to remove it from the vehicle.



STEP 8

Using socket extension(s), remove the screw holding the stock intake box to the grill inlet duct.

Tools Required: 10" Socket Extension or 4" 6" Socket Extension, 8mm Socket/Wrench



STEP 9

Firmly but carefully rock and lift the intake box free from the lower grommet and free the side rubber bushings from the side saddle bracket. Remove the intake box from the vehicle.



STEP 10

Remove the indicated grommet from the vehicle.

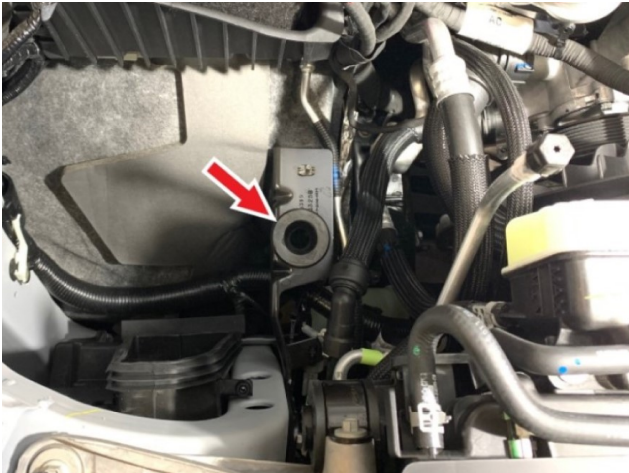

STEP 11

Remove the two screws that hold the saddle bracket and remove the bracket from the vehicle. Set one of the screws aside, it will be reused in Step 13.

Tools Required: 13mm Socket/Wrench



STEP 12

Install the rubber grommet (E) onto the tube support bracket (D) by pressing it into the large hole.



STEP 14

After attaching the provided coupler (G) to the intake tube (C) with a #74 hose clamp (F), install the intake tube into the vehicle by slipping the other end of the coupler around the turbo inlet. Gently guide the prong on the bottom of the tube into the grommet on the tube support bracket. Check the fitment of the bracket and tube and then tighten the bracket fully. This step ensures that the tube support bracket is installed in a position that will seat the tube correctly. After tightening down the bracket, remove the intake tube from the vehicle.

Tools Required: Ratchet, 13mm Socket



STEP 13

Install the tube support bracket (D) into the vehicle using the custom washer (K) and the screw removed in step 11. Slide the end of the bracket under the area of the vehicle where the grommet was removed from in step 10. Place the custom washer over the hole so that the step on the washer is seated inside the hole. Use the previously removed screw to finish the installation. Do not torque the screw down so that the bracket retains some play without falling out of position.

Tools Required: 13mm Socket/Wrench.

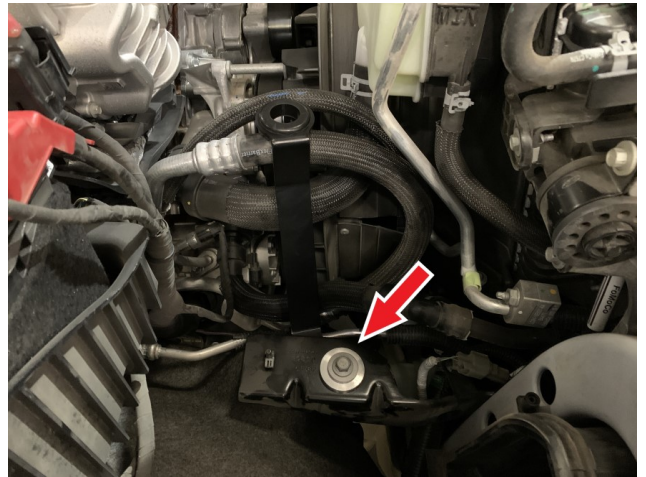

STEP 15

Remove the MAF sensor from the stock intake housing.

Tools Required: T20 Torx

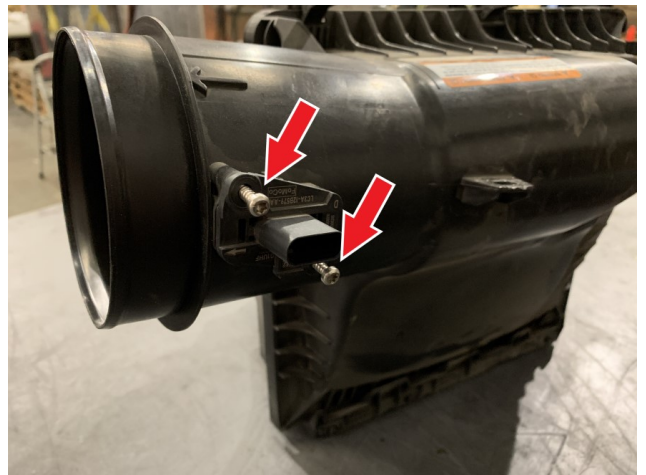

STEP 16

Assemble the remainder of the entire intake tube/filter assembly outside of the vehicle. Attach the filter (A) to the intake tube and secure it using a provided #104 hose clamp (B). Put the remaining #74 hose clamp loosely around the remaining side of the coupler. Make sure the location markings on the filter and tube line up to ensure proper alignment of the filter assembly.

Tools Required: 5/16" Nut Driver



STEP 17

Install the MAF sensor, MAF sensor pad (I) and MAF sensor pad gasket (J) onto the intake tube, securing them to the tube with the provided phillips head screws (H).

Tools Required: Phillips Screwdriver



STEP 18

Install the assembled intake kit into the truck by sliding the intake tube into place so that the tube's coupler slips around the turbo inlet. Secure the assembly by pushing the tube down so that the prong on the bottom side of the tube presses securely into the grommet of the bracket installed in step 13.



STEP 19

Finish securing the kit to the vehicle by tightening the #74 hose clamp over the coupler and around the turbo inlet.

Tools Required: 5/16" Nut Driver



STEP 20

Reattach the MAF harness to the MAF sensor by inserting the female end and engaging the white locking clip.

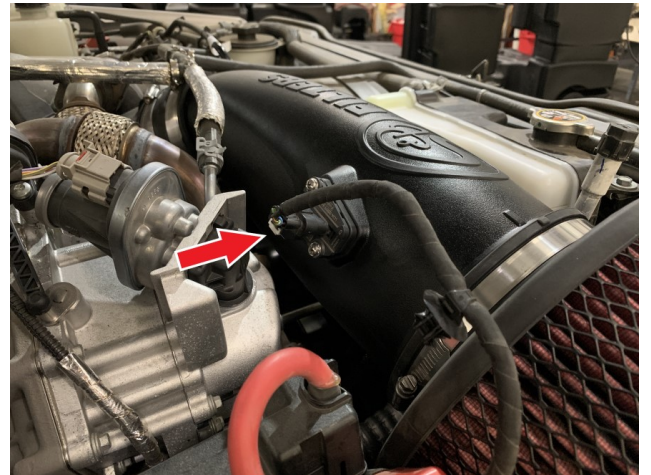

STEP 21

Visually inspect the installation of the intake kit. Make sure the tube is fully seated within the support bracket and that the tube did not push out the grommet during installation.

STEP 22

Reconnect the passenger side battery's positive terminal and both battery's negative terminals. Inspect your installation, make sure the kit is properly positioned and all fasteners are secured. S&B Filters recommends keeping all stock parts in case you would ever need to reinstall the stock intake. Affix the ID label near the intake kit. The installation is now complete.

